



GOVERNORS

- **MECHANICAL**
- **CENTRIVAC**
- **VELOCITY**

TABLE OF CONTENTS

MECHANICAL GOVERNORS

Description & Operation	2
Belt Driven	
Lubrication	3
Belt Adjustment	4
Linkage Adjustment	4
RPM Adjustment	4
No Load Surge Adjustment	7
Trouble Shooting	7
Camshaft Driven — (Super Duty 534)	
Description & Operation	9
Linkage Adjustment	9
RPM Adjustment	10
Sensitivity	11
Trouble Shooting	12
Crankshaft Driven	
I-4 GF Models	
Linkage Adjustment	14
RPM Adjustment	12
I-4 GH Models	
Linkage Adjustment	13
RPM Adjustment	13
CENTRIVAC GOVERNOR	
Description & Operation	14
RPM Adjustment	16
Trouble Shooting	16
VELOCITY GOVERNORS	
Description & Operation	17
RPM Adjustment	18
Altitude Compensator Adjustment	19

Industrial Engine Operations
Ford Parts and Service Division
P.O. Box 3080
Livonia, Michigan 48151

The descriptions and specifications contained in this manual were in effect at the time the book was released for printing. Ford Motor Company reserves the right to discontinue models at any time, or change specifications or design, without notice and without incurring obligation.

MECHANICAL GOVERNORS

Description & Operation

Mechanical governors date back many years and were originally developed to regulate the speed of steam engines. The basic principle of mechanical governors is the same as was employed originally.

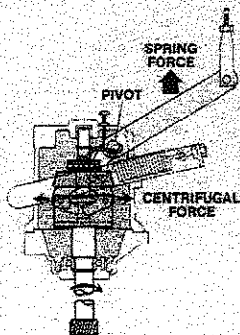

The governor shaft is driven by the engine at a fixed ratio. Flyweights rotating within the governor develop a centrifugal force outward in relation to the speed at which they rotate. The centrifugal force is counteracted by a calibrated spring outside of the governor housing. When the centrifugal force equals the spring force, the system is in balance and the engine speed remains fixed.

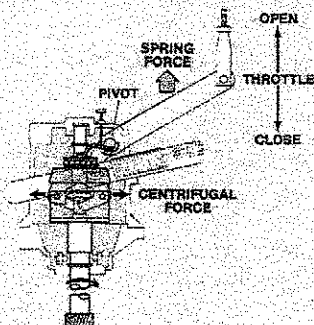

When the load is increased, the engine speed slows down and so do the governor weights which decreases the centrifugal force allowing the spring to open the throttle and again increase the engine speed. When the load is decreased the engine speed increases, which increases the centrifugal force of the governor weights overcoming the spring force, and pushes the throttle toward the closed position decreasing the engine speed.

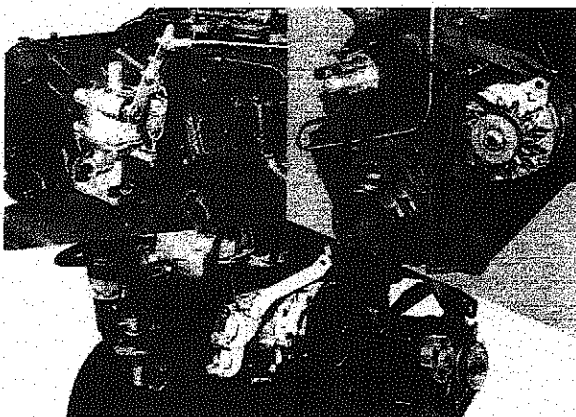

Mechanical governors come in various shapes and drives, but the principle of governing remains the same. Each type used by Industrial Engine Operations is covered in this booklet.

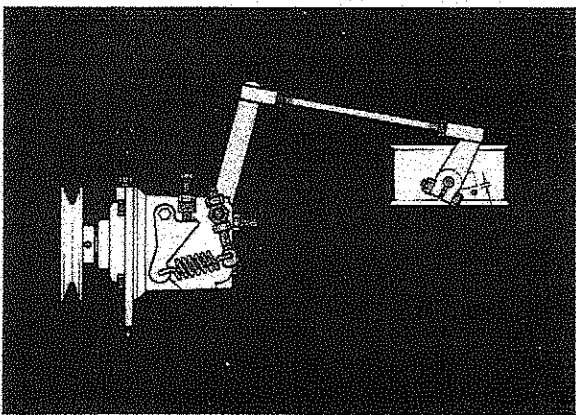

BELT DRIVEN

The belt driven governors come in several versions . . . The constant speed type, which is adjusted to operate at one fixed speed. The governor spring is connected between the spring lever and the speed adjusting lever. Spring tension, thus engine rpm, are adjusted by the speed adjusting screw.

The governor throttle lever has a flexible knee-action lever which allows the engine to be idled at a lower speed for starting and for standby service.

The variable speed type allows engine governor operation from idle to a maximum setting. The variable speed lever is actuated by the throttle cable, which in turn adjusts the spring tension and engine speed.

The throttle is generally a solid arm, but in some cases may contain the flexible knee-action joint for special applications.

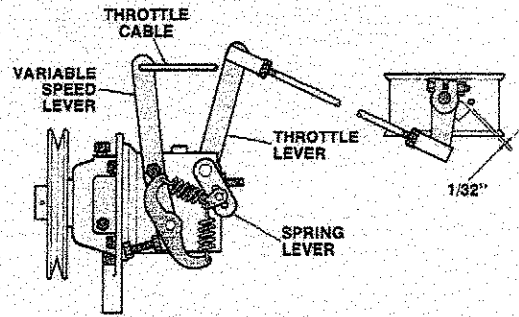

The belt driven governor must be driven by the engine at a fixed ratio. The governor pulley size and belt arrangement are determined by the engine application and the speed at which it is to be governed.

Slippage in either of these belts would permit the engine to run faster than the governor, thus permitting overspeed of the engine.

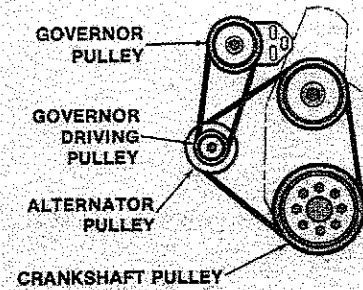

Tightening the drive belts too tight can cause early failure of the governor bearings. The belt tension should be set to specification with a belt tension gauge.

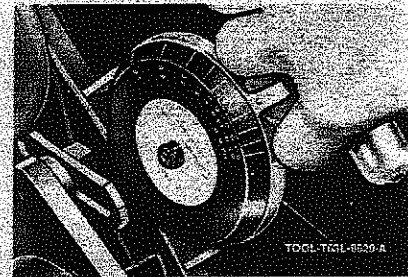

Lubrication

Another cause of governors bearing failure is the lack of proper lubrication. The oil level should be checked before initial startup and weekly during operation. Add it through the fill hole on top until it flows out the level hole.

Normally the same grade of oil that is used in the engine is acceptable for the governor. However, in single viscosity oils, never use anything heavier than 20 W as it will effect governor operation.

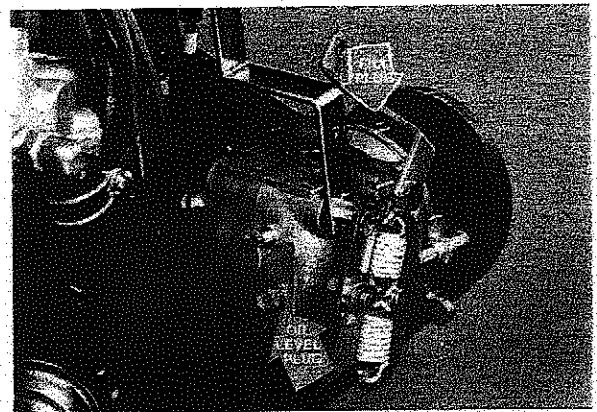

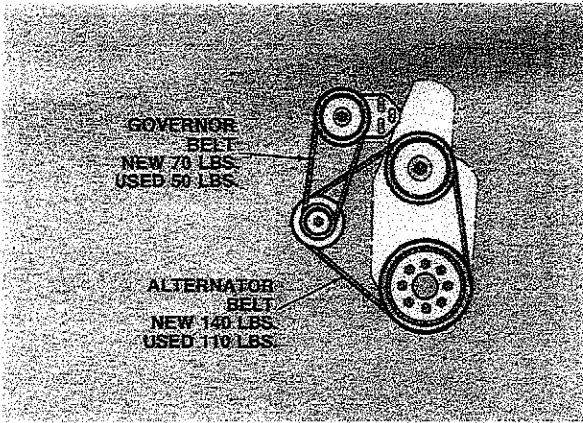

Belt Adjustment

Before attempting to diagnose any governing problem, verify all the adjustments. First, check the drive belts. Where the governor is driven by the alternator pulley, the condition of the alternator drive belt is just as important as the governor drive belt.

Check both belts to be sure they are not glazed or coated with some substance that can cause slippage.

Adjust the alternator belt first, then the governor belt. Notice that the specifications for the alternator belt is greater than that for the governor belt.

Note: Belt tension should be checked on a cold belt only. Any belt that has operated for ten minutes or more is considered a used belt.

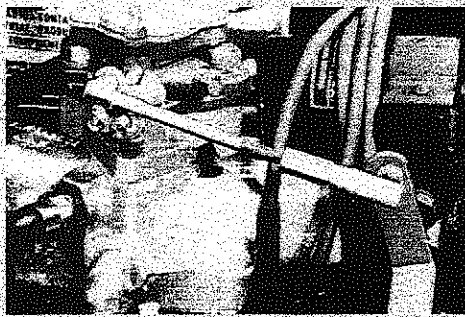

Linkage Adjustment

Next check the governor to carburetor linkage. . . It must be free but without excessive play. Any binding or play will cause erratic governor operation. The throttle rod length must then be adjusted to permit the governor to reach its maximum rpm position and the carburetor throttle plates, their wide open position. An improperly adjusted throttle rod can prevent proper governor response to load change.

Manually move the governor throttle lever to the maximum speed position with spring tension on the governor.

Check the gap between the carburetor throttle shaft lever and its maximum open position stop. It should be 1/32 to 1/4 inch wide.

If adjustment is necessary, loosen the control rod ball joint lock nuts, remove the rod from the carburetor throttle lever and adjust the length of the rod with the ball joints.

Install the throttle rod on the carburetor throttle lever and recheck the gap. Tighten the lock nuts.

The governor is now ready for the rpm adjustments.

RPM Adjustments

Attach a tachometer to the engine, then run the engine until it reaches normal operating temperature.

Disengage engine load and loosen the locknut on the governor high speed stop screw. The location of this screw will vary from governor to governor. Slowly pull the throttle to the desired maximum engine speed and adjust the high speed stop screw to maintain this speed.

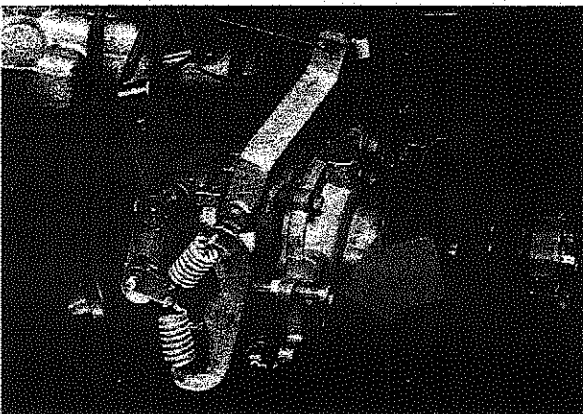

Proper governor operation requires a difference between full-load and no-load governed speed. This is called spread or sensitivity. Too small an rpm spread between the two speeds will cause governor hunting and surging. Too large a spread will cause low response to a load.

The normal rpm spread is 5 to 10%. This means if the desired full-load rpm is two thousand rpm, the no-load rpm can be 2100 to 2200 rpm.

Various types of adjustments are used for the spread. We will show you three of them here.

The first one we'll call the link type. The adjustment is made with the screw attaching the link to the throttle control lever.

If the governor is hunting and surging under load, the spread will have to be increased.

With the engine running under no load at maximum governed speed, loosen the rpm spread adjusting lock nut and turn the adjusting screw counterclockwise until engine speed decreases approximately 150 rpm; then tighten the lock nut. Preadjust the governor high speed stop screw to maintain the correct high speed under load. Precheck governor operation under full-load and no-load conditions to determine if operation is stabilized and sensitivity is satisfactory.

If the governor is slow to respond when the load is applied, the spread may be too great and have to be decreased.

Run the engine under no load at maximum governed speed. Loosen the rpm spread adjusting screw lock nut and turn the adjusting screw clockwise until engine speed increases approximately 150 rpm.

Readjust the governor high speed stop screw to maintain the correct high speed under load. Precheck governor operation under load and no load conditions.

**TOO SMALL
RPM SPREAD = GOVERNOR HUNTING
AND SURGING**

**TOO LARGE
RPM SPREAD = GOVERNOR LOW
RESPONSE**

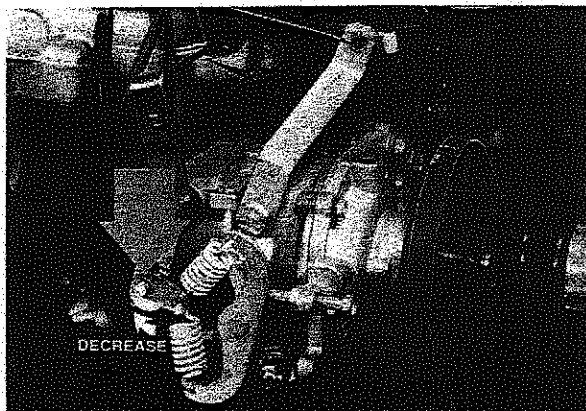
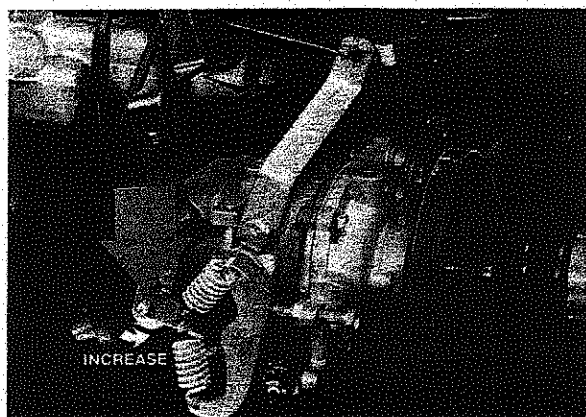

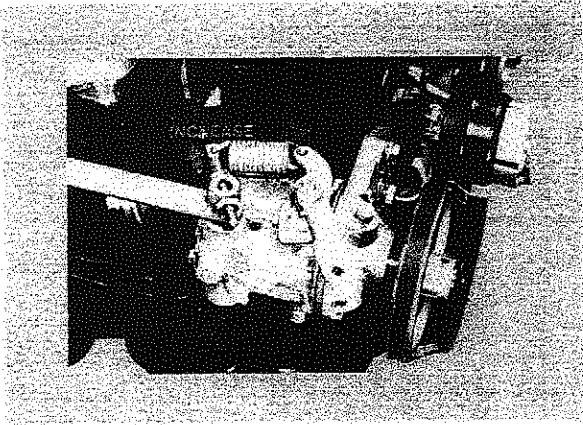

The second type of spread adjustment is the screw and hub type. Adjustment is made with the screw attaching the spring to the throttle control arm hub. To increase the spread, loosen the lock nut on the end of the screw away from the spring several turns. Now tighten the nut on the spring side of the hub to move the spring away from the lever hub. Tighten the lock nut.

Precheck governor operation under full load and no load conditions to determine if operation is satisfactory.

Readjust the governor high speed stop screw to maintain the correct high speed under load.

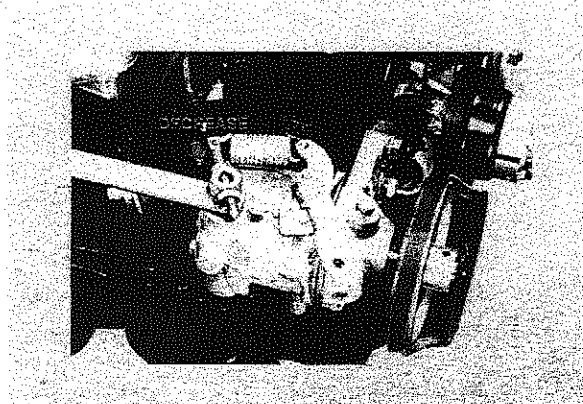

To decrease the spread, loosen the lock nut on the spring side of the hub several turns. Now tighten the other nut to move the spring nearer the lever hub. Tighten the lock nut.

Recheck governor operation under load and no load conditions.

Readjust the governor high spread stop screw to maintain the correct high speed under load.

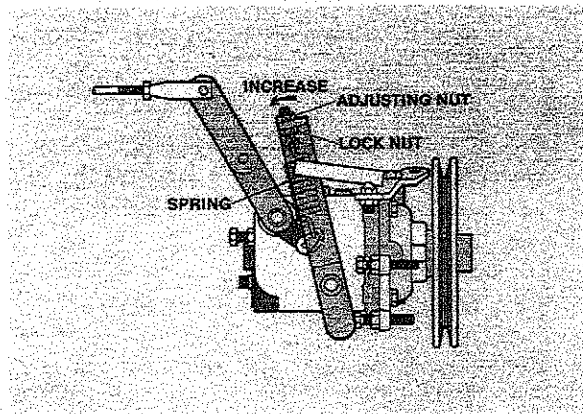

The third type of spread adjustment is the eye bolt type. Adjustment is made with the eye bolt that attaches the spring to the variable speed lever.

To increase the spread, loosen the lock nut and turn the adjusting nut counterclockwise until engine speed decreases approximately 150 rpm; tighten the lock nut.

Recheck governor operation under full load and no load condition.

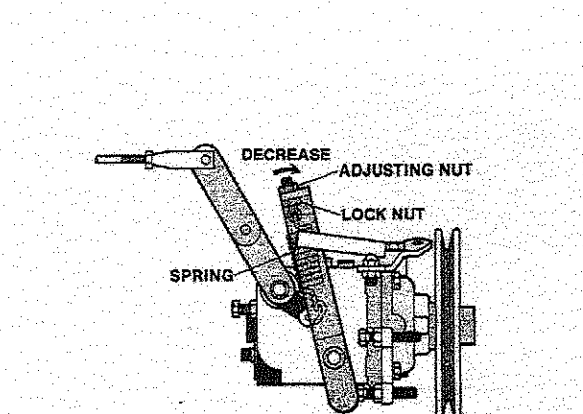

To decrease the spread, loosen the lock nut turn the adjusting nut clockwise until engine speed increases approximately 150 rpm. Tighten the lock nut.

Recheck governor operation under full load and no load conditions.

The low speed adjustment is made with the low speed adjustment screw, if the governor is so equipped, or with the carburetor idle speed adjustment screw.

Move the hand throttle or variable speed lever to the closed position. Turn the adjustment screw in or out until you can maintain the desired speed.

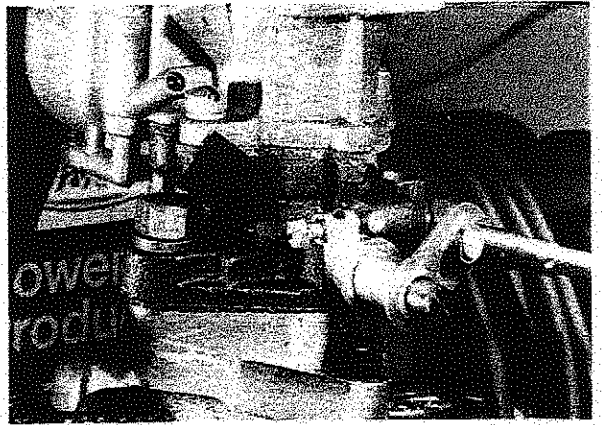

No Load Surge Adjustment

There is one more adjustment and that is the no load surge adjustment. It is set at the factory and rarely requires changing. If necessary, this adjustment can be used to prevent hunting and surging at no load speeds, provided the rpm spread adjustment is set properly.

To make the adjustment, increase the engine speed with the hand throttle to 75 rpm lower than the maximum no load desired control rpm. Then loosen the no load surge adjustment screw lock nut and turn the screw inward until rpm increases to the desired control rpm.

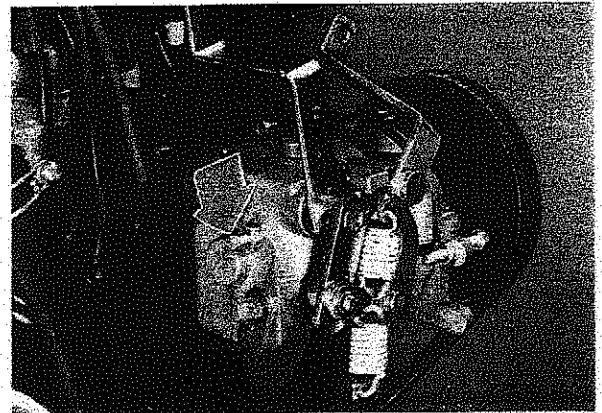

CAUTION: Do not turn the screw in all the way. It will interfere with proper governor operation and prevent the governor from returning the engine to idle speed.

Trouble Shooting

Trouble shooting a governor with a Full Load Surge, first increase the spread between full and no load. If this does not help, then shorten the throttle rod 2 or 3 turns. Then check for an excessively rich or lean fuel/air mixture at the carburetor. Also look for vacuum leaks.

There are two other conditions that can cause this problem that should have been checked before making the governor adjustments prior to diagnosis. They are excessively loose throttle rod ball joints or throttle rod binding or rubbing.

Full load Surge

- Increase Spread
- Shorten Throttle Rod two or three turns
- Check carburetor for excessively rich or lean mixture
- Check for vacuum leaks
- Check for loose ball joints on throttle rod
- Check throttle rod for binding or rubbing

No load surge — at maximum rpm

- Surge adjustment

No load surge at maximum rpm can be eliminated with the surge adjustment screw providing the no load and full load spread is properly set.

Engine overspeed — on accelerating

- Check carburetor linkage for excessive friction

Engine overspeed on accelerating can be caused by excessive friction in the carburetor linkage, throttle shaft and/or accelerator pump, if so equipped. The throttle rod may also be binding or rubbing, or the drive belt or belts may be slipping. Again the last two items should have been checked before making the adjustments.

Engine overspeed — on unloading

- Back out on load surge adjustment screw one or two turns
- Shorten throttle rod two or three turns
- Check for excessive amount of oil in the governor

If the engine overspeed on removal of the load, try backing out the no load surge adjustment screw 1 or 2 turns. If that doesn't do it, shorten the throttle rod 2 or 3 turns. Also, check for excessive amount of oil in the governor.

Governor does not respond to load changes

- Adjust throttle rod
- Back out no load surge screw and adjust
- Check governor flyweights

When the governor does not respond to load changes, adjust the throttle rod to the proper length. If problems still exist, back out the no load screw and adjust it per instructions.

Look for possible bent or fractured flyweights in the governor possibly caused by insufficient lubrication or overspeeding.

CAMSHAFT DRIVEN Description & Operation

The mechanical driven governors are driven by the camshaft, crankshaft or power take off gears.

The camshaft driven governor is used on the 534 CID Super Duty engines.



A direct mechanical linkage connected from the governor output shaft to the carburetor throttle arm lever synchronizes the throttle and governor through a clutch assembly inside the throttle operating housing, located on the side of the carburetor. Under normal operating conditions and the engine rpm below the governor set point, the clutch assembly will be engaged. Once the engine rpm reaches the set point of the governor, the output shaft of the governor becomes the controlling factor and will disengage the clutch assembly. At this point, the maximum engine rpm is determined by the governor.

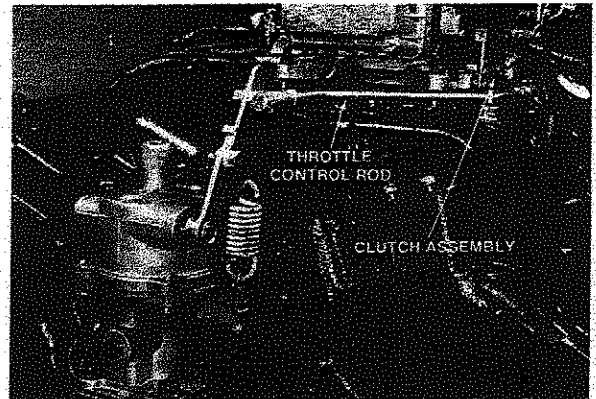

When the engine rpm falls below the governor set point, the clutch re-engages, and the throttle linkage once again controls the rpm of the engine.

Linkage Adjustment

Before making any adjustments, perform a preliminary check of the throttle control rod. It must be free but without excessive play. Any binding or play will cause erratic governor operation.

To make the adjustment, disconnect the throttle control rod at the carburetor. Loosen the lock nut on the spring adjusting eye bolt. Tighten the adjusting nut finger tight, then turn it in 2 additional turns to preload the spring. Tighten the lock nut.

Move the throttle to the wide open position and connect the governor throttle control rod to the carburetor control arm.

Adjust the governor throttle control rod so that the governor throttle control auxiliary lever is full forward. This is the wide open throttle position. Next, shorten the rod 1 full turn. This will position the throttle plates slightly off wide open position and will avoid compression of the control rod linkage.

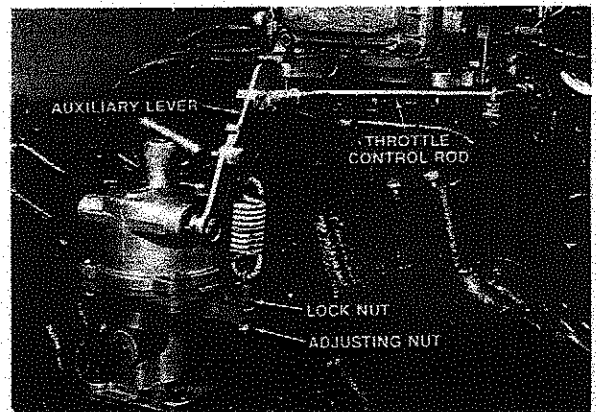

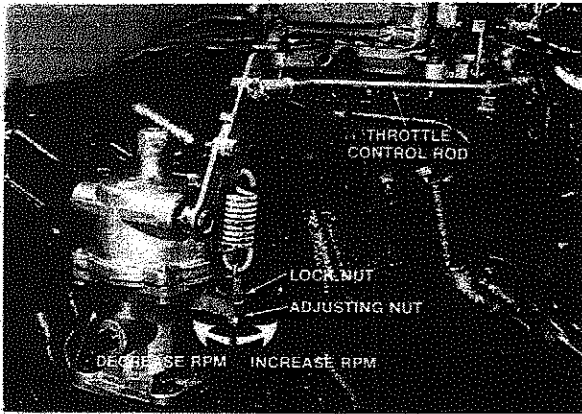

RPM Adjustment

To adjust the rpm, operate the engine until normal operating temperature has been reached. Place the throttle in the full wide open position and adjust the rpm by increasing the tension of the governor main spring to increase the rpm, and by decreasing the tension to decrease the rpm. Loosen the lock nut several turns. Tighten or loosen the adjusting nut to obtain the desired rpm. Tighten the lock nut.

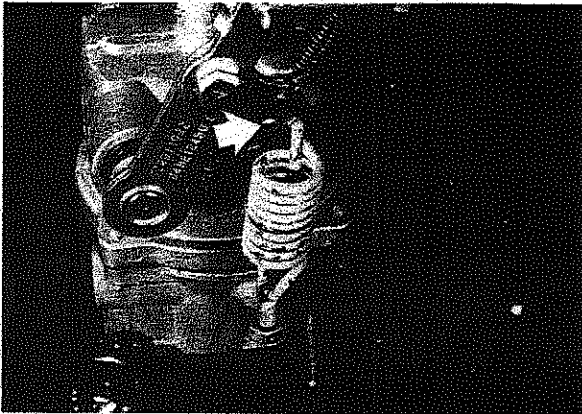

Sensitivity

Sensitivity of the governor can be increased by installing the governor spring in the hole closest to the governor lever arm pivot. Adjust the governor speed after changing the spring position.

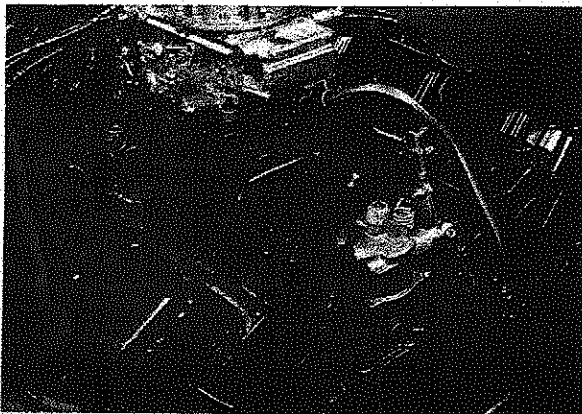

Trouble Shooting

Trouble shooting is accomplished by making the preliminary check and adjustments.

If the governor still does not perform to specifications, it will have to be removed and repaired.



CRANKSHAFT DRIVEN I-4 GF Models

The crankshaft driven mechanical governor is used on the I-4 Industrial gasoline (GF) models. It is located on crankshaft between the pulley hub and the crankshaft gear under the front cover.

Before attempting to set the engine governed speed, some preliminary steps have to be done.

Linkage Adjustment

Check the governor to carburetor linkage . . . It must be free but without excessive play. Any binding or play will cause erratic governor operation.

The throttle rod length must then be adjusted to permit the governor to reach it's maximum speed position and the carburetor throttle plates, their wide open position. An improperly adjusted throttle rod can prevent proper governor response to load changes.

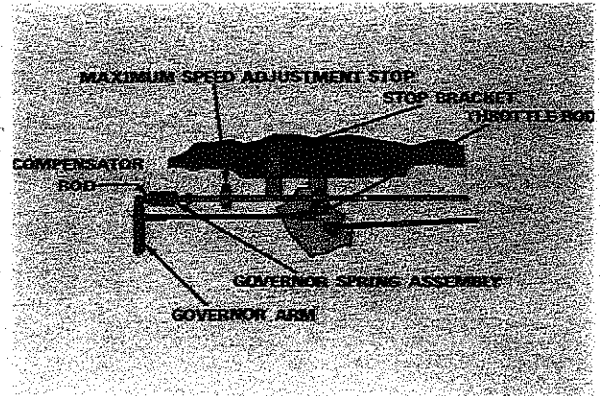

Check the throttle rod length by disconnecting it at the carburetor and moving the carburetor throttle lever to the full open position. If the throttle rod cannot be connected to the carburetor without moving the governor lever, the rod must be adjusted.

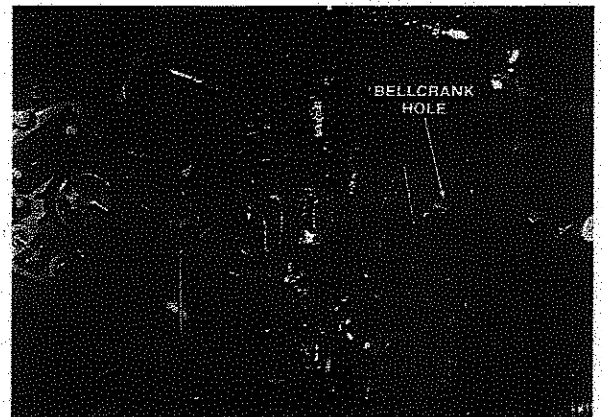

To adjust the rod, loosen the lock nut at the clevis. With the carburetor lever in full open position, lengthen or shorten the rod as necessary to connect it to the throttle lever. Tighten the lock nut.

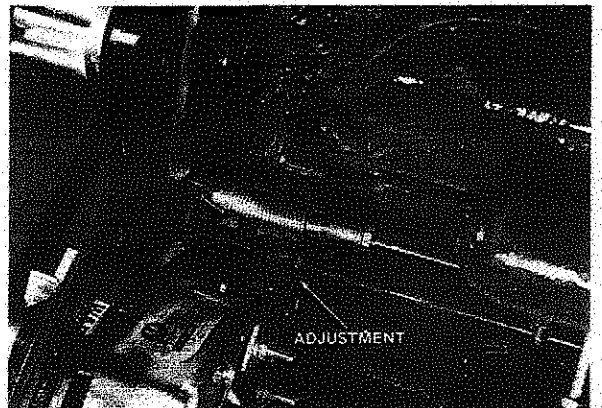

With the engine at normal operating temperature and the idle speed at 600 rpm, the governor lever should be contacting the end of the compensator rod with a minimum of spring tension. Adjust the spring as required.

This spring and adjustment control the spread between full load and no load rpm.

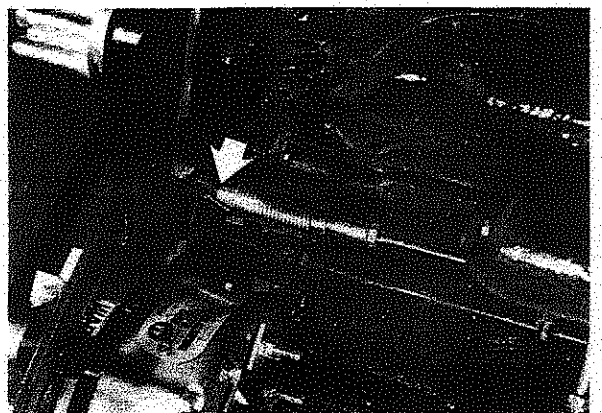

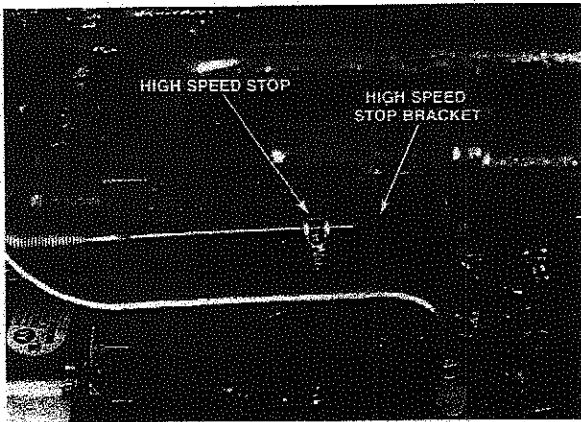

RPM Adjustment

To make the high speed no load adjustment, loosen the lock nut on the high speed stop. With the engine running under no load advance the throttle until the tachometer registers the correct rpm. Then slide the high speed stop against the stop bracket located on the engine block. Tighten the lock nut on the high speed stop.

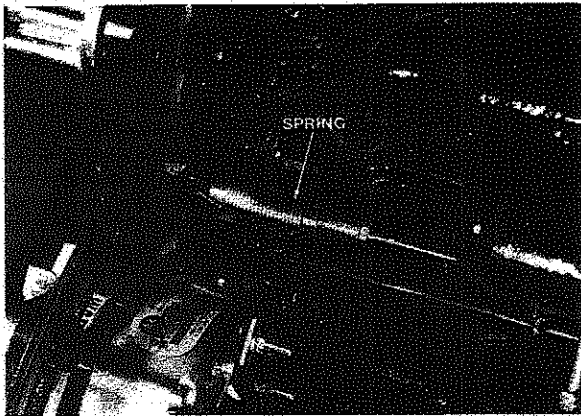

For closer regulation under light loads, the linkage can be adjusted with the following procedure.

Without the engine running, pull the throttle open until the spring stretches to 5 inches if the full load is to be 2800 rpm, or to 4-7/16 if the full load is to be 2500 rpm.

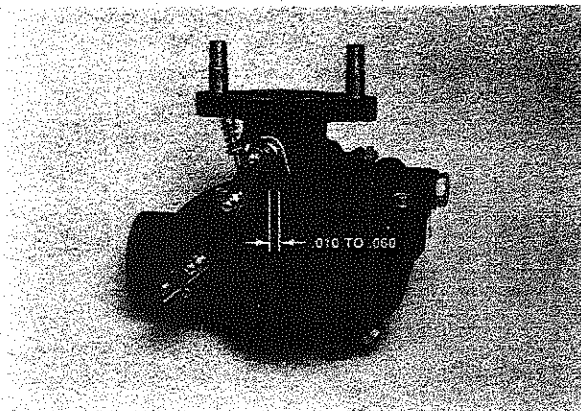

With this spring tension against the governor lever, adjust the throttle rod to provide .010 to .060 between the carburetor bellcrank and wide open stop.

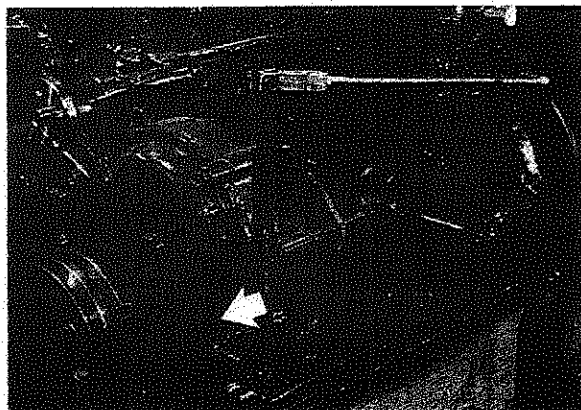

I-4 GH Models

The forklift (GH) models of the I-4 gasoline engines have a PTO driven governor.

It is located on the front of the power takeoff and is attached to the PTO gear.

Perform the preliminary checks before attempting any rpm adjustments.

Linkage Adjustment

Check the governor to carburetor linkage . . . It must be free but without excessive play. Any binding or play will cause erratic governor operation.

The throttle rod length must then be adjusted to permit the governor to reach it's maximum speed position and the carburetor throttle plates, their wide open position. An improperly adjusted throttle rod can prevent proper governor response to load changes.

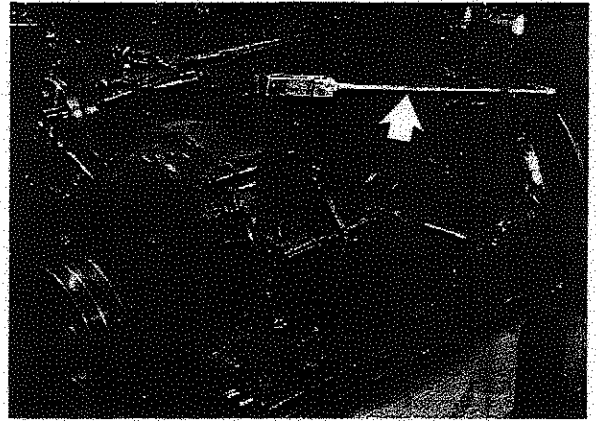

Check the throttle rod length by disconnecting it at the carburetor and moving the carburetor throttle lever to the full open position. If the throttle rod cannot be connected to the carburetor without moving the governor lever, the rod must be adjusted.



To adjust the rod, loosen the lock nut at the clevis. With the carburetor lever in full open position, lengthen or shorten the rod as necessary to connect it to the throttle lever. Tighten the lock nut.

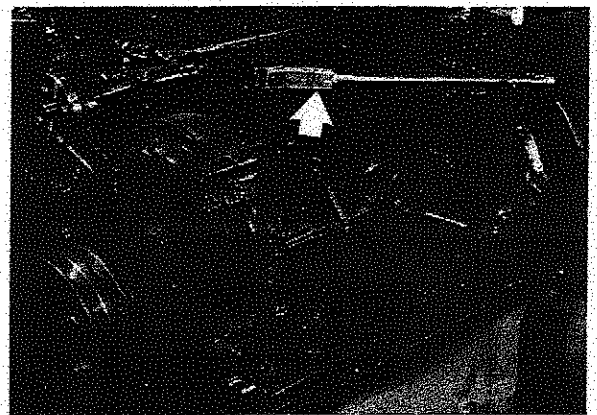

RPM Adjustment

Maximum speed is controlled by the governor spring.

To make the adjustment, start the engine and bring it up to normal operating temperature. With a tachometer attached, run the engine up slowly until the throttle is at wide open throttle. DO NOT EXCEED 3000 RPM. Adjust the spring tension to set the no load rpm to specification.

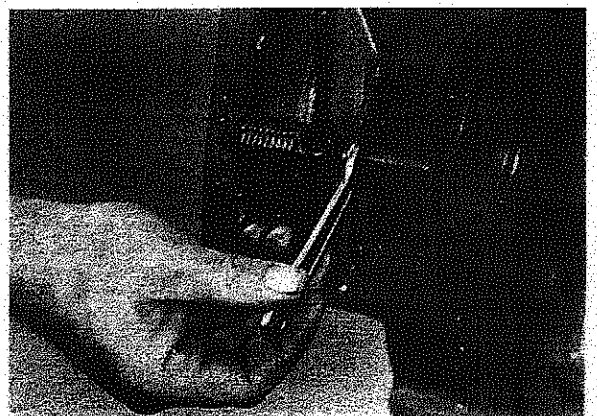

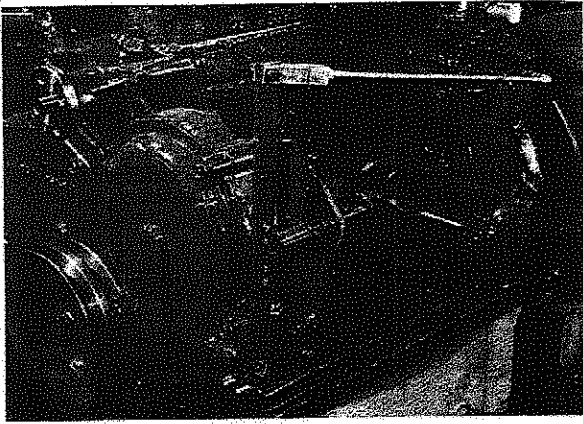

Trouble shooting is accomplished by making the preliminary check and adjustments. If the governor still does not perform to specifications, it will have to be removed and repaired.

CENTRIVAC GOVERNOR

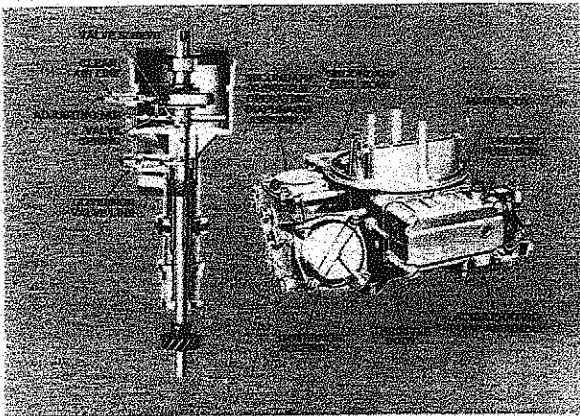

Description & Operation

The centrivac governor is known as a vacuum governor. It consists of a throttle actuating mechanism on the carburetor and the controlling unit built into the distributor housing and driven by the distributor shaft.

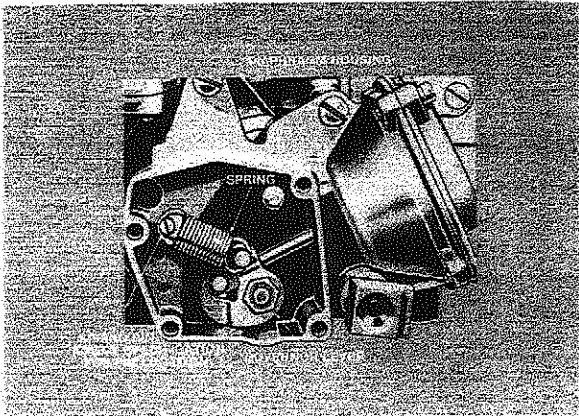

The throttle actuating mechanism on the carburetor has a diaphragm assembly, governor spring, and governor lever assembly. The spring and diaphragm are linked together by the governor lever which is attached to the carburetor primary throttle shaft.

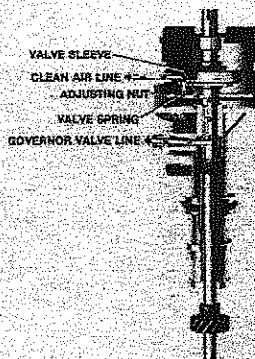

The controlling unit in the distributor contains a centrifugal operated governor valve. The valve is driven by the distributor mechanism. It regulates the amount of vacuum in the actuating mechanism diaphragm assembly by closing an air bleed as engine rpm reaches the governed setting.

The operator controls the throttle plates in the usual manner below governed speeds through a clutch arrangement on the carburetor throttle body. When governed speed is reached, a combination of venturi and manifold vacuum acts on the governor diaphragm to close the throttle plates. Two calibrated bypass jets in the vacuum passages meter the vacuum from the venturi and the manifold to provide the correct balance for proper operation of the governor.

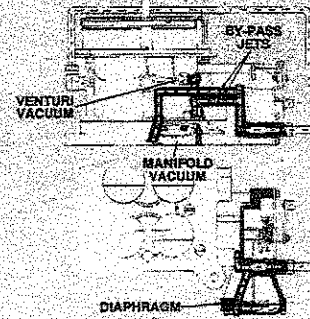

At speeds below governing rpm, this vacuum is weakened by air from the governor valve in the distributor so that premature governing action will not occur. Filtered air from the carburetor air cleaner enters the governor system through a passage in the carburetor to the controlling unit. A combination of vacuum from the venturi and manifold transmitted through the governor system passages on the carburetor, draws the air through the governor valve and back to the governor diaphragm on the carburetor.

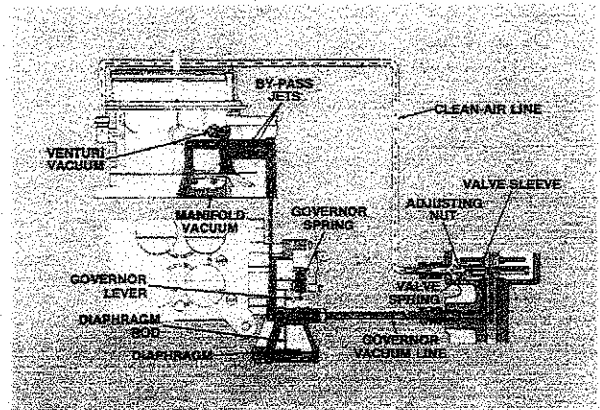

In the controlling unit, centrifugal force acting on the governor valve, which has kept pace with engine speed, overcomes the tension of the valve spring and partially retards the flow of air to the throttle actuating mechanism when governed speed is reached.

The air flow is retarded by the valve sleeve being thrown outward by centrifugal force, and thus partially closing the air inlet on the governor valve shaft.

The partial blocking of the air inlet reduces the amount of air bleeding through to the diaphragm on the carburetor, thus allowing manifold and venturi vacuum to operate the diaphragm.

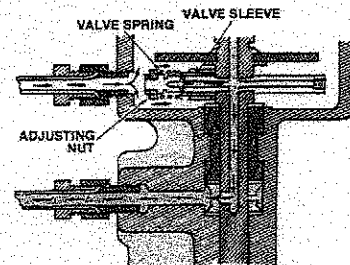

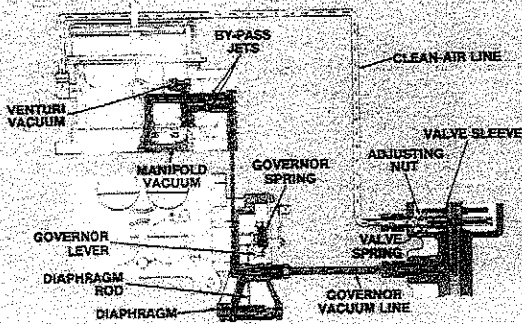

As the vacuum acting on the diaphragm becomes stronger, the diaphragm moves the governor lever against the tension of the governor's spring to close the throttle plates. The governed engine speed is held for constant load by centrifugal force on the valve balanced against the tension of the valve spring. Any slight change in engine speed due to load restriction will cause the governor valve to react immediately, either increasing or decreasing the amount of air bleeding through the governor valve orifice. A change in amount of air bleed will in turn, cause an instant response from the diaphragm to increase or decrease the throttle plate opening. When the accelerator is released, control is taken from the governor by the external throttle lever, and the return spring in the accelerator pedal linkage closes the throttle pedal to bring the engine to a desired low speed.

RPM Adjustment

With a tachometer connected, operate the engine until normal operating temperature has been reached.

Operate the engine at wide open throttle and note the engine speed registered. Stop the engine and remove the adjusting hole plug from the controlling unit housing. With the ignition switch off, crank the engine until the governor adjusting nut is aligned with the adjustment hole.

Turn the adjusting nut clockwise to increase speed and counterclockwise to decrease speed. One full turn of the adjusting nut will change top speed about 150 rpm. Repeat this procedure until the desired top speed is reached.

Install the adjusting hole plug and tighten it securely.

Attach a new locking wire and lead seal to the adjusting hole plug and the adjacent fin.

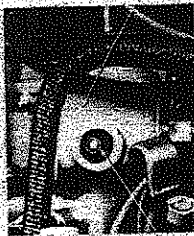

Trouble Shooting

- Engine will not run over an idle.

The governor spring in the throttle actuating mechanism pulls the throttle plates open, so this spring may be improperly installed or broken.

The clutch arrangement on the carburetor throttle body may also be the problem.

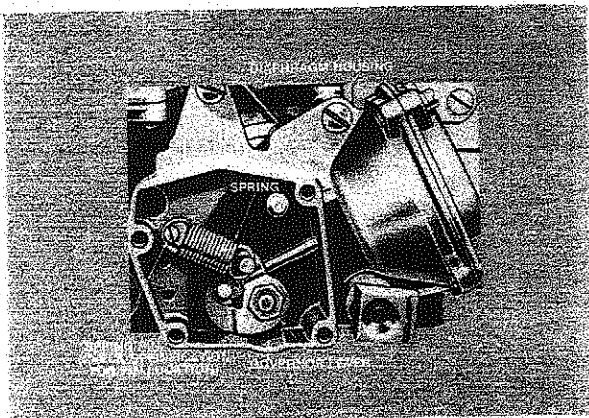

- Engine will not reach governed rpm.
Eliminate the controlling unit by disconnecting the governor vacuum line at the carburetor.
Be careful dirt does not enter the vacuum fitting.
Check if engine will reach required rpm. If not, the problem is in the carburetor. If the engine will reach required rpm, the problem is in the governor.
Reconnect the vacuum line and proceed with adjusting the governor valve in the distributor. If it cannot be adjusted, the distributor will have to be removed and the valve and passages cleaned.

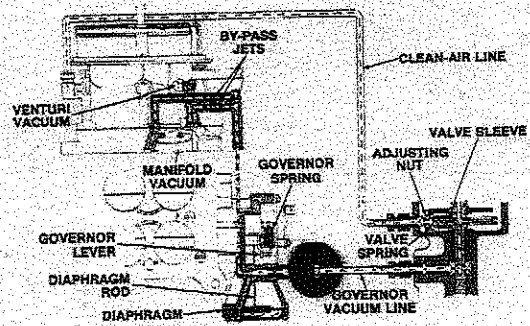

- Engine overspeeds. Eliminate the controlling unit by disconnecting the governor vacuum line at the carburetor. Increase the engine rpm to specified maximum and then seal the open end of the vacuum fitting in the carburetor with your finger. The throttle actuating mechanism should reduce the engine rpm.

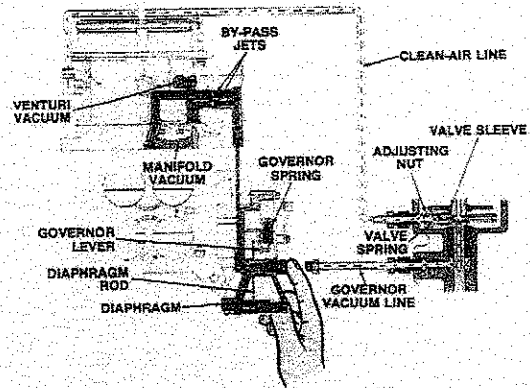

If the rpm did not decrease, the vacuum diaphragm or passages have a leak and will have to be repaired.

If the rpm did decrease, the actuating mechanism is operating and the problem is in the controlling unit.

Connect the vacuum line to the carburetor.

Disconnect the clean air line at the distributor.

Increase the engine rpm to the specified maximum and then seal the open end of the clean air fitting in the distributor with your finger. The governor should reduce the engine rpm.

If the rpm did not decrease, the distributor housing or governor vacuum line has an excessive vacuum leak. If the rpm did decrease, the governor should be adjustable.

If it cannot be adjusted, the centrifugal valve is sticking open and must be repaired.

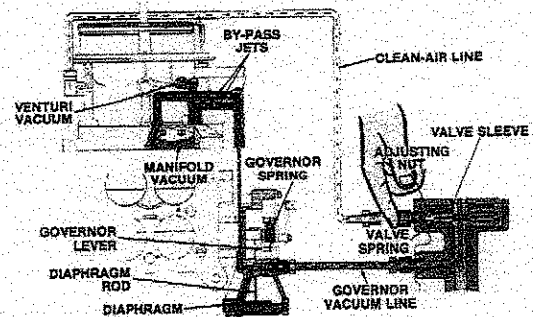

VELOCITY GOVERNOR

Description & Operation

The velocity governor is a single unit mounted between the carburetor and the intake manifold. It is operated by a combination of manifold vacuum and air flow past the governor throttle valves.

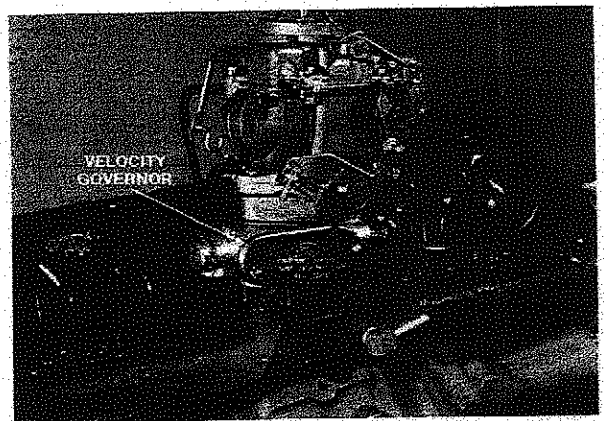

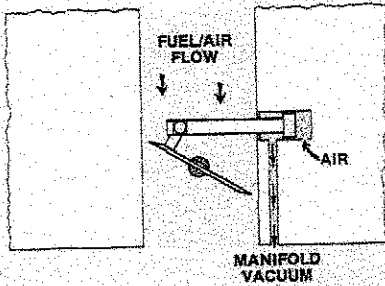

The governor throttle valves are offset in the throttle bore so that the combined force of the manifold vacuum and the fuel/air flow through the bores has greater effect on the larger, upstream area of the valves.

This forces the governor throttle valves to move toward the closed position restricting the fuel/air flow.

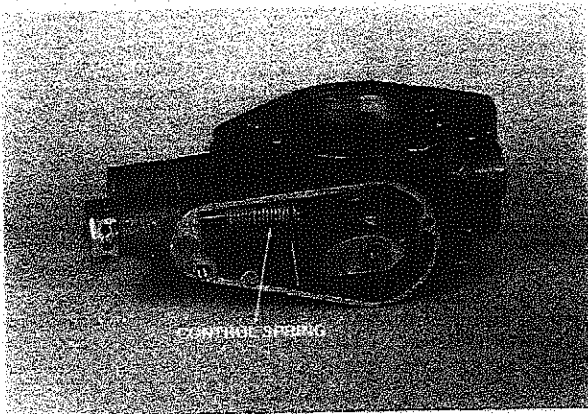

The closing action of the governor throttle valves is opposed by the control spring.

The control spring is attached to the governor throttle valve shaft cam. The cam provides a balance between the closing action of the throttle valves and the opening action of the control spring at all engine speeds.

RPM Adjustment

Adjustment of the velocity governor is made with a tachometer attached and the engine at normal operating temperature.

Operate the engine at wide open throttle and check the rpm.

If adjustment is required or desired, remove the governor seal.

To increase the rpm, turn the cap counterclockwise.

When the adjustment is complete, stop the engine, seal the cap and remove the tachometer.

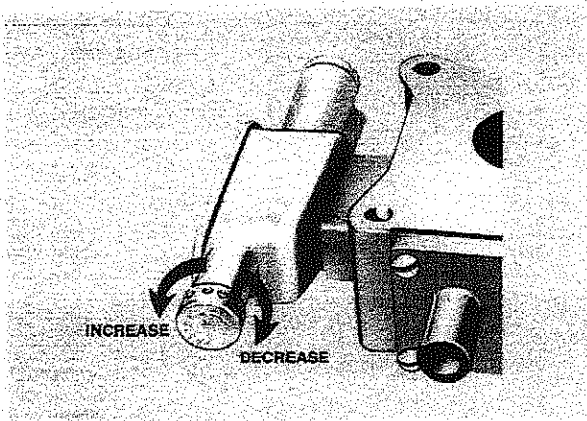

Altitude Compensator

The characteristic of velocity-type governor is that the regulated engine speed increases in direct proportion to any increase in the altitude in which the engine is operated. This also causes a proportionate increase in the spread between full load and no load setting. A normal sea level no load setting of 3000 engine rpm becomes 3300 engine rpm at 5000 feet above sea level. The 300 engine rpm spread at sea level becomes a 500 engine rpm spread at 5000 feet above sea level.

The altitude compensating governor can be adjusted to compensate for variations due to altitude. With the exception of the altitude compensating adjustment, the description and operation of this governor is the same on the conventional velocity governor.

On units equipped with an Altitude Compensating governor, the Varying Altitude Adjustment is made on engines that are operating at or near sea level and altitudes above 2000 feet. First make the no load adjustment as previously explained. Then, using the adjusting cap only, adjust the no load speed for the anticipated altitude by turning the adjustment cap 1/4 turn in the clockwise direction for each 1000 foot difference between the altitude. The adjustment is made for the maximum anticipated operating altitude.

The Constant Altitude Adjustment is made on engines that are going to be operated at a constant altitude above 2000 feet. Cut the governor seal wire and remove the adjusting cap. Do not rotate the adjusting cap during removal.

Use a mirror and a light to observe the position of the slots in the adjusting bushing. Hold the tool in the proper position to engage the adjusting bushing slots and carefully insert the hex-shaped center post of the tool in the hex-head of the adjusting screw. Push the tool inward until the tangs on the tool engage the slots in the adjusting bushing. If the tool will not engage in the adjusting bushing slots, note the position of the tool and rotate the tool slightly in either direction until engagement is achieved. If it is necessary to rotate the tool more than 1/6 turn (1 flat of the hex head) to accomplish engagement, rotate the tool back to its insertion position and pull the tool out. Rotate the tool 1/6 turn in the direction required to achieve engagement and re-insert it.

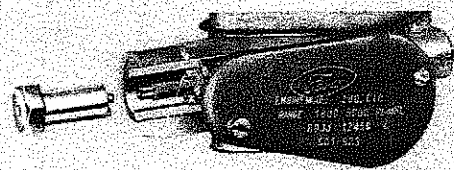
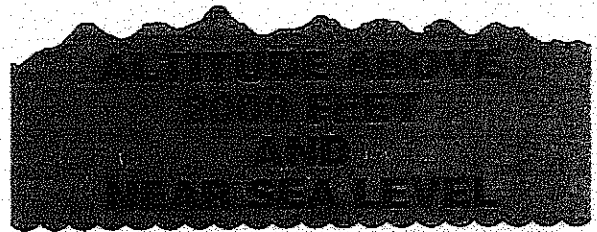

AVERAGE OPERATING ALTITUDE — FEET	AMOUNT OF TOOL ROTATION
2000	1/2 TURN (180°)
3000	1/2 TURN (180°)
4000	2/3 TURN (240°)
5000	1/2 TURN (180°)
6000	1/2 TURN (180°)

1/2 OR 1/3 TURN ROTATIONS EQUIVALENT TO ONE FLAT OF THE TOOL HEX HEAD.

The altitude adjustment table specifies the amount from the factory setting that the tool should be rotated to adjust the velocity governor for altitude operation. For an increase in the average altitude of operation, rotate the tool the specified amount in the counterclockwise direction.

Remove the tool and install the adjusting cap. Do not turn the adjusting cap. Install the tachometer and check and adjust the no load setting of the governor with the adjusting cap. If the altitude adjustment was done properly, the no load and full load spread will be within specifications. Seal the adjusting cap to the governor body.



Trouble shooting is using the proper adjusting procedure. If the governor cannot be adjusted it will have to be replaced.

However, be sure the proper governor has been installed for the engine application and rpm it is to operate at.

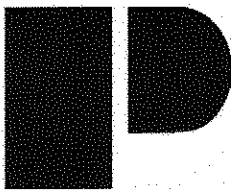

Pitt Auto Electric Company
 4085 Alpha Drive, Allison Park, PA 15101
 Phone: 1-800-245-0711 * Fax: 1-800-551-5908

INVOICE

INVOICE	
5198756	
Invoice Date	Page
5/14/2015 15:52:08	1 of 1

Customer ID: 116675

Bill To:

AIS CONSTRUCTION EQUIPMENT CORP
 ATTN: GAIL, ACCOUNTS PAY MANAGER
 600 AIS DRIVE SW
 GRAND RAPIDS, MI 49548
 USA

Ship To:

MDC CONTRACTING
 05481 US 31 SOUTH
 CHARLEVOIX, MI 49720
 USA

PO Number		Terms Description		Net Due Date	Disc Due Date	Discount Amount	
T50514CW77		1.5 % 10 days Net 30		6/13/2015	5/24/2015	3.30	
Order Date	Pick Ticket No	ORDER NUMBER	Special Info		Taker		
5/14/2015 15:31:48	3184305	1204458			BILL ANKER		
Quantities			UOM	Item ID Item Description	Price UOM	Unit Price	Extended Price
Ordered	Shipped	Remaining	Unit Size		Unit Size		
<i>Delivery Instructions:</i> NEXT DAY AIR <i>Carrier:</i> UPS Next Day <i>Tracking #:</i> 1Z1837660106018004							
1.00	1.00	0.00	EA	ISU 8-9710 5012	EA	219.9420	219.94
			1.0	PUMP ASM; WATER	1.0000		
<i>Supersedes:</i> ISU 8-9712 3330							

Total Lines: 1

Total Freight In: 0.00

Total Freight Out: 55.33

SUB-TOTAL: 219.94

TOTAL FREIGHT: 55.33

TAX: 0.00

AMOUNT DUE: 275.27

U.S. Dollars

REMIT PAYMENT TO:

Pitt Auto Electric Company
 4085 Alpha Drive
 Allison Park, PA 15101

Return Information

Authorization is required to return any item on this invoice. Call 800-245-0711 for an authorization number.